



6 FLAME

WELDING TOOLS AND ACCESSORIES

- ◆ Hoses / Automatic roller for oxygen hoses..... 89
- ◆ Quick action coupling 90 to 91
- ◆ Cutting nozzles and other flame accessories 92



Gas	Ø (mm)	Maximum pressure (bar)	Coil length (m)	To order
Single hoses				
Acetylene	6.3 x 12	10	5	W000010055
Oxygen	6.3 x 12	10	5	W000010056
Acetylene	6.3 x 12	10	10	W000010081
Oxygen	6.3 x 12	10	10	W000010057
Acetylene	6.3 x 12	10	20	W000010058
Oxygen	6.3 x 12	10	20	W000010059
Acetylene	6.3 x 12	10	40	W000010060
Oxygen	6.3 x 12	10	40	W000010061
LPG*	6.3 x 12	10	20	W000010052
LPG*	6.3 x 12	10	40	W000010062
Acetylene	10 x 16	20	10	W000010064
Oxygen	10 x 16	20	10	W000010065
Acetylene	10 x 16	20	20	W000010066
Oxygen	10 x 16	20	20	W000010067
Acetylene	10 x 16	20	40	W000010068
Oxygen	10 x 16	20	40	W000010069
LPG	10 x 16	20	20	W000010053
LPG/Acetylene*	10 x 16	20	40	W000010071
Oxygen	8 x 14	20	50	W000010079
Acetylene	8 x 14	20	50	W000010080
Argon	6.3 x 12	10	40	W000010072
Argon	10 x 16	20	40	W000010073
Twin hoses				
TWIN (Oxygen - Acetylene)	6.3 x 12	10	20	W000010077
TWIN (Oxygen - Acetylene)	6.3 x 12	10	40	W000010063
TWIN (Oxygen - Acetylene)	8 x 14	20	50	W000010078
TWIN (Oxygen - Acetylene)	10 x 16	20	20	W000010054
TWIN (Oxygen - LPG)*	10 x 16	20	40	W000010076

* Propylene excluded



0876-071_ret



2017-348



2017-350



2017-228

THE DATE PRINTED ON THE HOSE IS THE MANUFACTURING DATE

AUTOMATIC ROLLER FOR OXYGEN HOSES

TUBEREEL



Automatic roller for twin hoses diameter 8 or 10 mm.

- ◆ Automatic roller for twin hoses diameter 8 or 10 mm.
- ◆ Allows the operator to choose the hose length suitable to his application
- ◆ Maximum length for inside diameter 8 mm: 20 m
- ◆ Maximum length for inside diameter 10 mm: 15 m
- ◆ Provided without hoses

To order W000260575

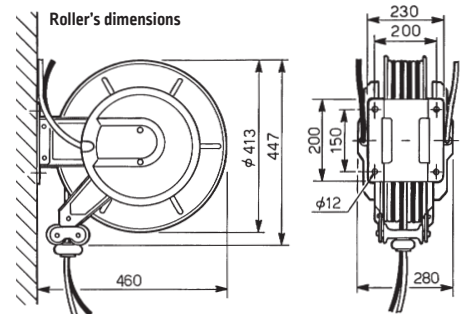

On the ground

On a wall

From the ceiling

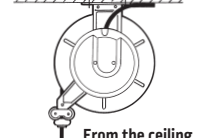
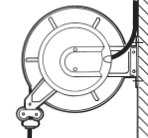
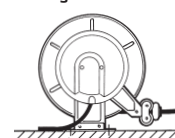

QUICK ACTION COUPLINGS

QUICKMATIC II



QUICKMATIC II is the new range of quick couplings designed and manufactured by Weldline.

Safety, Performance and Easy to Use are keys words that characterize this new range.

QUICKMATIC II is available in several versions:

- ◆ By type of gas - presence of a mechanical coding
- ◆ For mounting on the regulator, between pipes and on the blowpipe
- ◆ With integrated FBA (Flash Back Arrestor)

Advantages:

- ◆ **Safety**
 - Gas flow stopped during disconnection due to an internal mechanism
 - Specific design limiting accidental disconnections
- ◆ **Ease of use and ergonomics**
 - «Push System» connection with automatic locking
 - Studied design to allow to use with one hand
- ◆ **Performances**
 - 4 levels of tightness
 - Compatible with any welding or cutting blowpipe thanks to limited pressure losses

To order

Connection between hoses **A**

QUICKMATIC II	Ø hoses (mm)	To order	
		Female connector	Male connector
1 Fuel Gas	6.3 and 10	W000011002	W000011005
	6.3 and 8	W000386369	
2 Oxygen	6.3 and 10	W000011001	W000011004
	6.3 and 8	W000386370	
3 Neutral gas (Argon, ...)	4 and 6.3	W000011003	W000011006

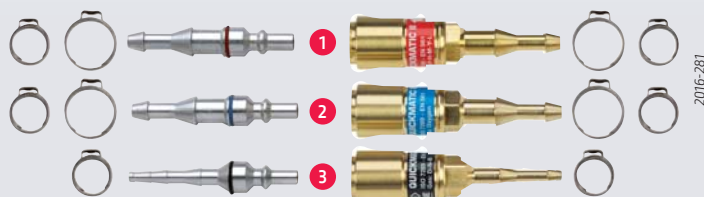

Also available in kits :

Females kit



To order W000011015

Males kit



To order W000011016

Female / Male kit

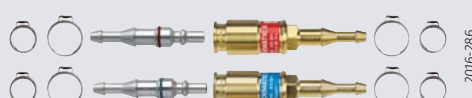

To order W000011017

Regulator connection **B**

QUICKMATIC II	Thread	Ø hoses (mm)	To order	
			Female connector	Male connector
4 Fuel gas	M16 x 150 Left	6 and 10	W000011008	W000011005
	3/8" Left		W000011011	
5 Oxygen	M16 x 150 Right	6 and 10	W000011007	W000011004
	3/8" Right		W000011010	
	1/4" Right		W000011009	
6 Neutral gas (Argon, ...)	12 x 100 Right	4	W000011012	W000011006
	3/8" Right		W000386358	
	1/4" Right		W000386359	

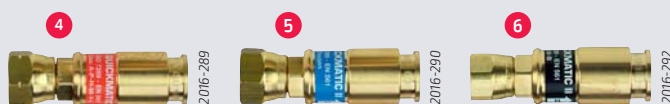

Recommendations for use

Flame installation

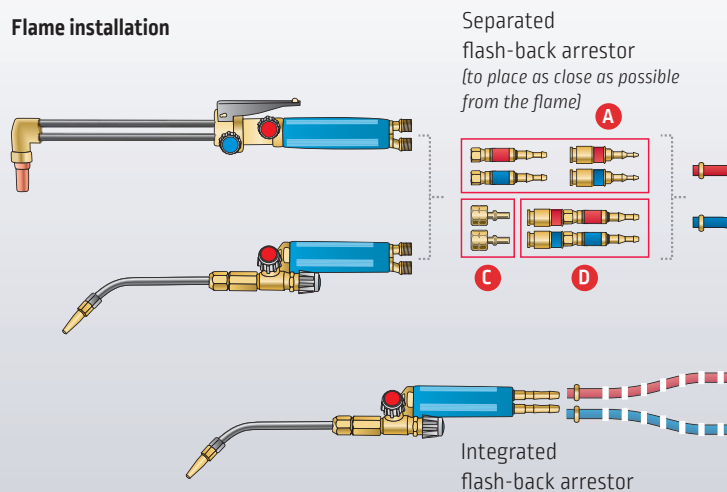

Separated flash-back arrestor (to place as close as possible from the flame) **A**

Integrated flash-back arrestor

Blowpipes' entry connection **C**

QUICKMATIC II	Thread	To order	Male connector
7 Fuel gas	16 x 150 Left	W000011014	
Oxygen	16 x 150 Right	W000011013	

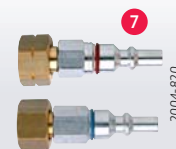

QUICKMATIC II with integrated FBA **D**

SECURTOP 662	Inlet hoses (mm)	Outlet	To order
Oxygen	Ø 6.3 and 10	QUICKMATIC II female	W000386367
	Ø 6.3 and 8		W000386368
Fuel Gas	Ø 6.3 and 10		W000386365
	Ø 6.3 and 8		W000386366
Kit Oxygen + Fuel gas	Ø 6.3 and 10		W000400169
	Ø 6.3 and 8		W000400170



Visit our factory

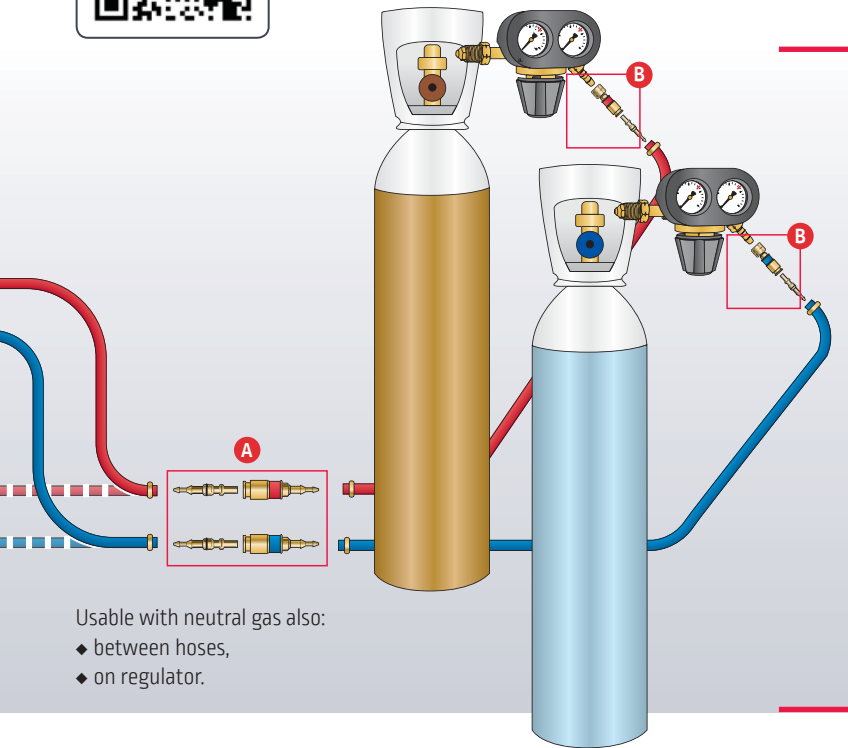

Usable with neutral gas also:

- ◆ between hoses,
- ◆ on regulator.

Mounting on thread

QUICKMATIC II	Thread	To order	Female coupling
8 Fuel gas	16x150 Left	W000386360	
	3/8 Left	W000386362	
9 Oxygen	16x150 Right	W000386361	
	3/8 Right	W000386363	
	1/4 Right	W000386364	



2016-295



2016-296

Technical characteristics and usable gases:

Label		Gas		Pressure max. (bar)	Max Flowrate (m³/h)*
Letter	Color	Name	Letter		
F	Red	Acetylen	A	1,5	14
		Propane	P	5	22
		Hydrogen	H	10	215
		Methane	M	5	40
		MPS	Y	5	24
		Propylene	L	5	22
O	Blue	Oxygen	O	20	65
N	Black	Air	D	20	90
		CO ₂	B		73
		Nitrogen, neutral gas	N		92

* Maximal flowrate without flash-back arrestor



FLAME

6

CUTTING NOZZLES AND ACCESSORIES

G1 cutting nozzles and IC cutting nozzles

G1 profile	Gauge (mm)	Cutting thickness (mm)	IC profile
Acetylene			Acetylene



0327-033

W000262059	7/10	3-10	W000262089
W000262060	10/10	10-25	W000262091
W000262061	12/10	25-50	W000262093
W000262062	16/10	50-80	W000262094
W000262063	20/10	80-120	W000262095
W000262064	25/10	120-200	W000262096
W000262065	30/10	200-300	W000262097



0327-031

Propane			Propane
W000262066	7/10	3-10	W000262098
W000262067	10/10	10-25	W000262099
W000262068	12/10	25-50	W000262100
W000262069	16/10	50-80	W000262101
W000262070	20/10	80-120	W000262102
W000262071	25/10	120-200	W000262105
W000262072	30/10	200-300	W000262106

PROTECFLAM

Heat shield protection for walls and floors during gas welding, brazing or soldering.

PROTECFLAM
Single use
200 x 250 mm

Asbestos free



2006-397

To order W000271449

Blister pack of 3 shields

PROTECFLAM TECH

Very flexible (*memory effect*)
Long life duration - Both sides usable
200 x 250 mm

No toxic fumes release

To order W000276078



2005-272R

Tip cleaners

Used to clean welding and cutting nozzles to restore nozzle performance. Contains a range of round needle files in a metal carry case.



To order W000290900

THERMISHIELD



See page 96

2009-249

Spark lighter



To order W000010978



Traditional tool with five renewal flints.



To order W000211924

Gun model with ten renewal flints.

Inspection mirrors

Mirror with magnetic stand

To order W000010557



To order W000010558

Spare part: mirror.

Circular telescopic mirror



2009-297

2009-298

For all angle viewing. Fast and accurate visual inspection of hidden areas with an almost limitless number of positions.

To order W000273291